

# PARTS CATALOGUE / TECHNICAL GUIDE

## Cal. V657A

### [SPECIFICATIONS]

| Item                            | Cal. No.         | V657A  |
|---------------------------------|------------------|--|
| Movement                        |                  |  <p style="text-align: center;">(x 1.0)</p>  |
| Movement size                   | Outside diameter | ø29.5 mm<br>26.0 mm between 3 o'clock and 9 o'clock sides  |
|                                 | Casing diameter  | ø28.8 mm   |
|                                 | Height           | 3.7 mm   |
| Time indication                 |                  | <ul style="list-style-type: none"> <li>• Three hands (hour, minute and second)</li> <li>• Chronograph hands (minute, second and 1/10 second)</li> <li>• Date calendar</li> </ul>   |
| Driving system                  |                  | Step motor (3 pcs.)  |
| Additional mechanism            |                  | <ul style="list-style-type: none"> <li>• Stopwatch function                             <ul style="list-style-type: none"> <li>• Measures up to 60 minutes in 1/10 second increments</li> <li>• Split time measurement</li> </ul> </li> <li>• Date calendar                             <ul style="list-style-type: none"> <li>• Instant setting device for date calendar</li> <li>• Train wheel setting device</li> <li>• Electronic circuit reset switch</li> <li>• Demonstration movement of the hands</li> </ul> </li> </ul> |
| Loss/gain                       |                  | Monthly rate at normal temperature range: less than 20 seconds   |
| Regulation system               |                  | Nil  |
| Measuring gate by quartz tester |                  | Any gate can be used.  |
| Battery                         |                  | SEIKO SR920SW, Maxell SR920SW, Sony SR920SW, Eveready 371, Matsushita SR920SW<br>Battery life is approximately 2 years.<br>Voltage: 1.55V  |
| Jewels                          |                  | 0 jewel  |

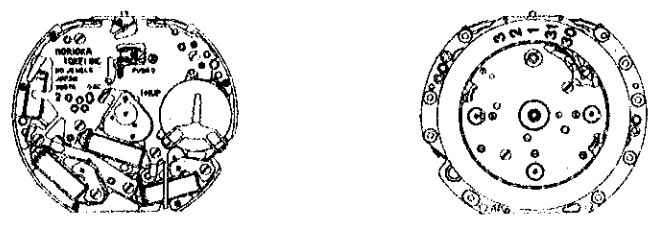

# PARTS CATALOGUE

Cal. V657A

Disassembling procedure Figs. : ① → ⑤⑧

Reassembling procedure Figs. : ⑤⑧ → ①

Lubricating: Types of oil      Oil quantity

 Moebius A       Normal quantity  
 Moebius V

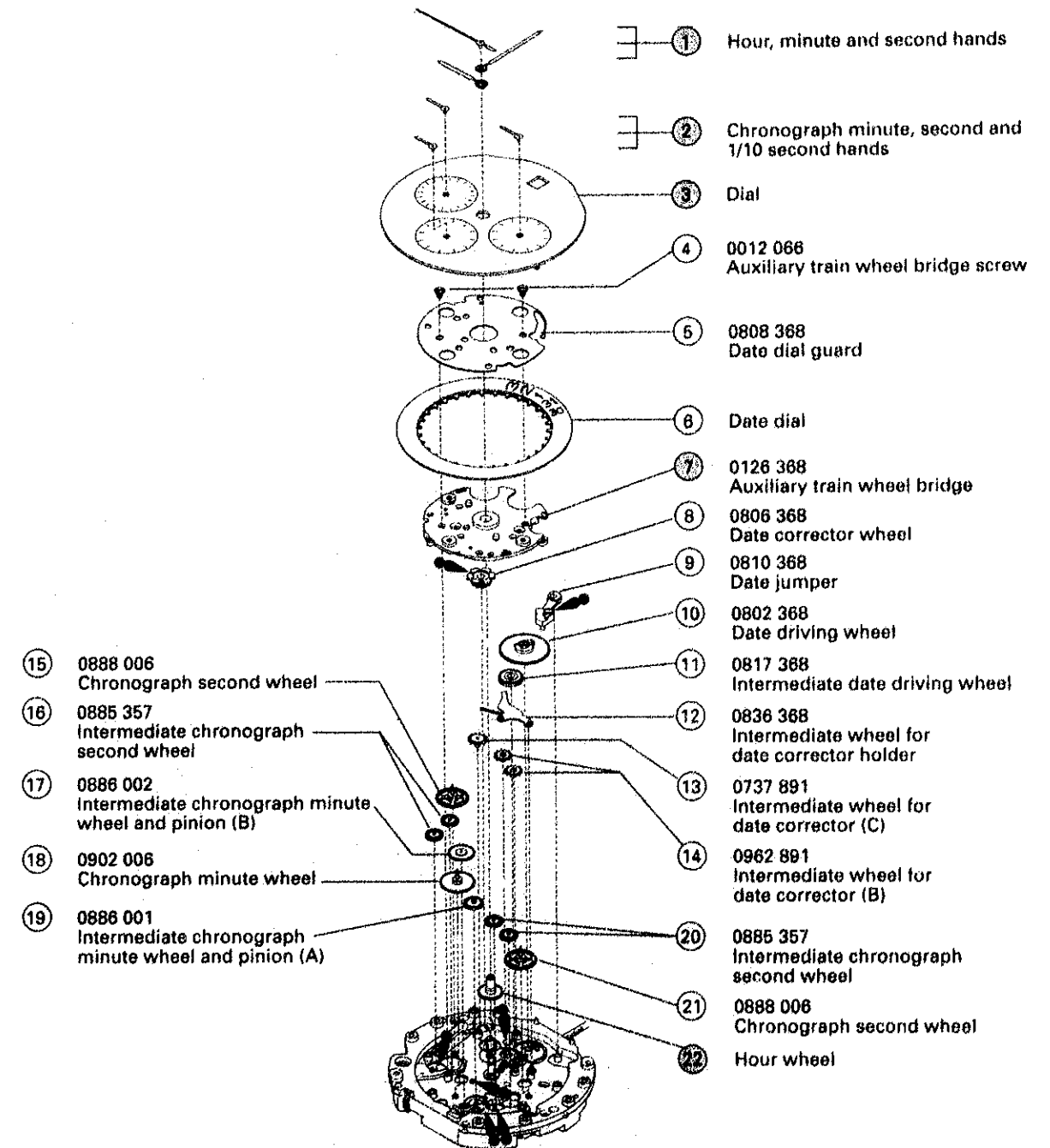

 Please see the remarks on the following pages.

# PARTS CATALOGUE

Cal. V657A

# PARTS CATALOGUE

Cal. V657A

23 Battery  
(See the front page.)

24 Winding stem

25 0012 066  
Switch spring screw

26 Switch spring

27 4003 029  
Circuit block

28 4270 357  
Battery connection (-)

29 0012 066  
Printed circuit board (B) screw

30 4201 288  
Printed circuit board (B)

31 0012 066  
Train wheel bridge (B) screw

32 0125 331  
Train wheel bridge (B)

33 0701 357  
Fifth wheel and pinion (B)

34 4146 177  
Step rotor (B)

35 4002 891  
Coil block

36 4239 357  
Rotor stator

37 0012 066  
Train wheel bridge (B) screw

38 0125 331  
Train wheel bridge (B)

39 4146 177  
Step rotor (B)

40 4002 891  
Coil block

41 4239 357  
Rotor stator

42 0701 357  
Fifth wheel and pinion (B)

43 0125 330  
Train wheel bridge (A)

44 Fourth wheel and pinion

45 0231 890  
Third wheel and pinion

46 0701 890  
Fifth wheel and pinion (A)

47 4146 890  
Step rotor (A)

48 0261 176  
Minute wheel and pinion

49 Center wheel and pinion

50 0281 890  
Setting wheel

51 4002 891  
Coil block

52 4239 357  
Rotor stator

53 0391 368  
Train wheel setting lever

54 0383 368  
Setting lever

55 0384 470  
Yoke

56 0282 890  
Clutch wheel

57 0962 890  
Intermediate wheel for date corrector (A)

58 0100 368  
Main plate

0012 066

- Auxiliary train wheel bridge screw (2 pcs.)
- Switch spring screw (5 pcs.)
- Train wheel bridge (B) screw (2 pcs.)
- Printed circuit board (B) screw (1 pc.)

➡ Please see the remarks on the following pages.

## Remarks:

- 22 Hour wheel
- 44 Fourth wheel and pinion
- 49 Center wheel and pinion

Those parts specified above are determined based on the design of cases. Check the case number and refer to "CASING PARTS CATALOGUE" to choose a corresponding one.

### • Discrimination of the hands installation height

Cal. V657A watch has numerals printed on the dial and movement to indicate the hands installation height. When repairing, refer to the table below.

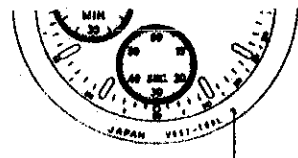
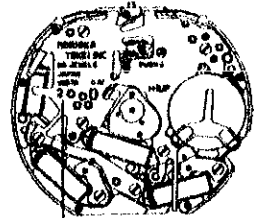
| Discrimination   | Height     | Standard type  |  |
|------------------|------------|--|--|
|                  |            | 2  |  |
|                  | Printed on | Dial   | Movement   |
| Printed position |            |  |  |
|                  |            | The numeral is printed on the extreme right.   | The numeral is printed below the calibre number.                                     |

\* Hands installation height can be discerned from the shape of the following parts. Refer to the table below.

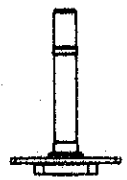
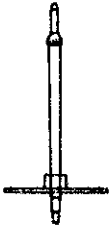
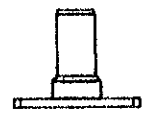
| Numeral for discrimination | Center wheel and pinion   | Fourth wheel and pinion   | Hour wheel  |
|----------------------------|---|---|---|
| 2                          | <br>0221 368 | <br>0241 407 | <br>0271 407 |

- 24 Winding stem 0351 892

The type of winding stem is determined based on the design of cases. Check the case number and refer to "CASING PARTS CATALOGUE" to choose a corresponding winding stem.

- 26 Switch spring 4245 342

Use with the movement bearing the discrimination numeral "2".

# TECHNICAL GUIDE

Cal. V657A

- The explanation here is only for the particular points of Cal. V657A.
- For the repairing, checking and measuring procedures, refer to the "TECHNICAL GUIDE, GENERAL INSTRUCTIONS".

## I. STRUCTURE OF THE CIRCUIT BLOCK

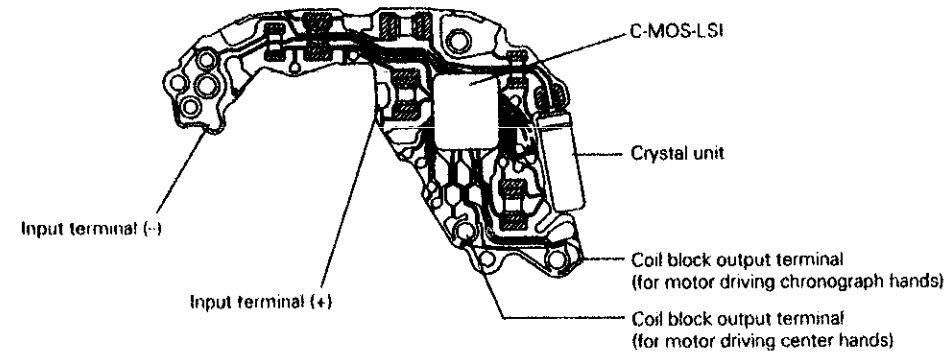

## II. REMARKS ON INSTALLING THE BATTERY

- After the battery is replaced with a new one, or after the battery is re-installed following repairing procedures, be sure to short-circuit the AC terminal of the circuit block and the battery connection (+) with conductive tweezers to reset the circuit as shown in the illustration below. (When checking the current consumption, short-circuit with power supplied from an external source.)

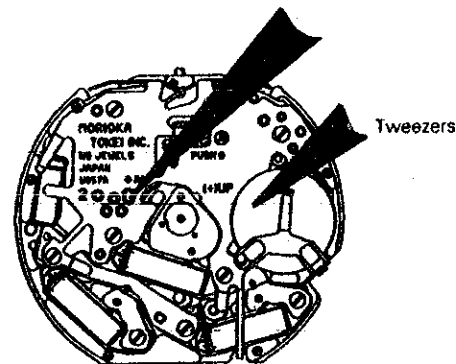

- The circuit can be reset with the complete watch. Follow the procedure below.

1. Pull out the crown to the second click.
2. Press buttons "A" and "B" at the same time for approximately 2 seconds.
  - \* The chronograph second hand makes half a revolution counterclockwise and then returns to where it was. The chronograph 1/10 second hand makes a full revolution clockwise and stops.

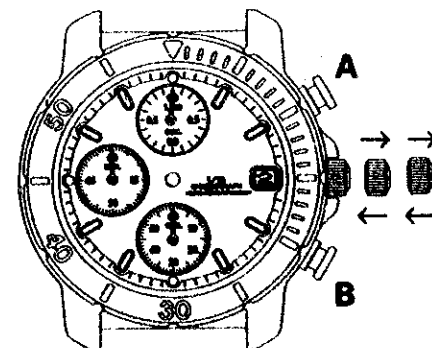

# TECHNICAL GUIDE

Cal. V657A

3. Press button "A" repeatedly to reset the chronograph 1/10 second hand to the "0" position. Press button "B" repeatedly to reset the chronograph second and minute hands to the "0" position.
  - \* The chronograph minute hand moves correspondingly with the chronograph second hand.
  - \* The hands move quickly if the respective buttons are kept pressed.
4. Turn the crown to set the desired time and push the crown back in to the normal position.

## III. REMARKS ON DISASSEMBLING AND REASSEMBLING

Use the universal movement holder for disassembling and reassembling.

- ① Hour, minute and second hands
- ② Chronograph minute, second and 1/10 second hands

Since a plastic main plate is used, place the movements on a flat metal plate or the like, and then install the hands at the position as specified below. Before doing so, check that the battery is installed in the movement.

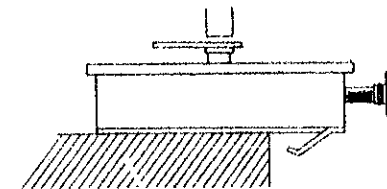

| Hands to be installed               | Positions at which hands are installed |
|-------------------------------------|--|
| Hour, minute and second hands       | 12 o'clock position                    |
| Chronograph 1/10 second hand        | "0" position                           |
| Chronograph minute and second hands | 60 minute/second position              |

- ③ Dial

Pry up the dial at the two recessed portions indicated in the illustration using a screwdriver.

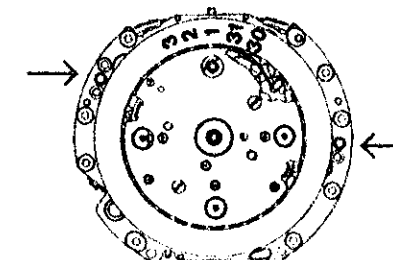





# TECHNICAL GUIDE

Cal. V657A

## ⑦ Auxiliary train wheel bridge

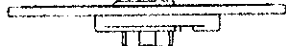
### • Setting position (calendar mechanism)

|   |   |  |   |
|---|---|--|---|
| ⑧ 0806 368<br>Date corrector wheel  | ⑬ 0737 891<br>Intermediate wheel for date corrector (C)                           | ⑩ 0802 368<br>Date driving wheel   | ⑭ 0962 891<br>Intermediate wheel for date corrector (B)                             |
|  |  |  |  |

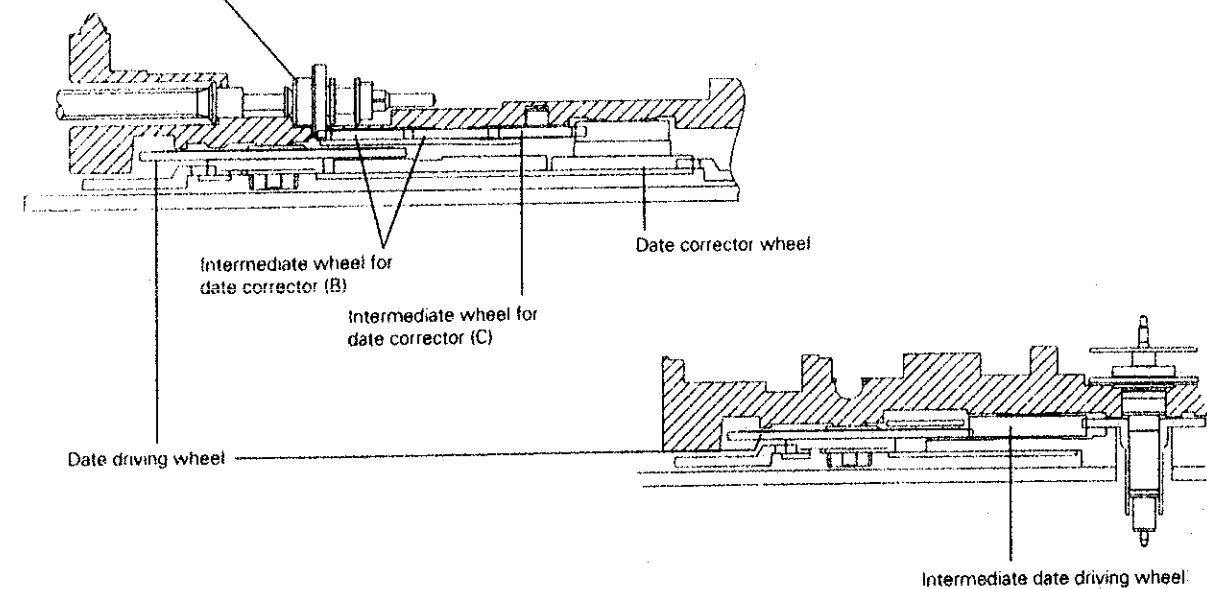
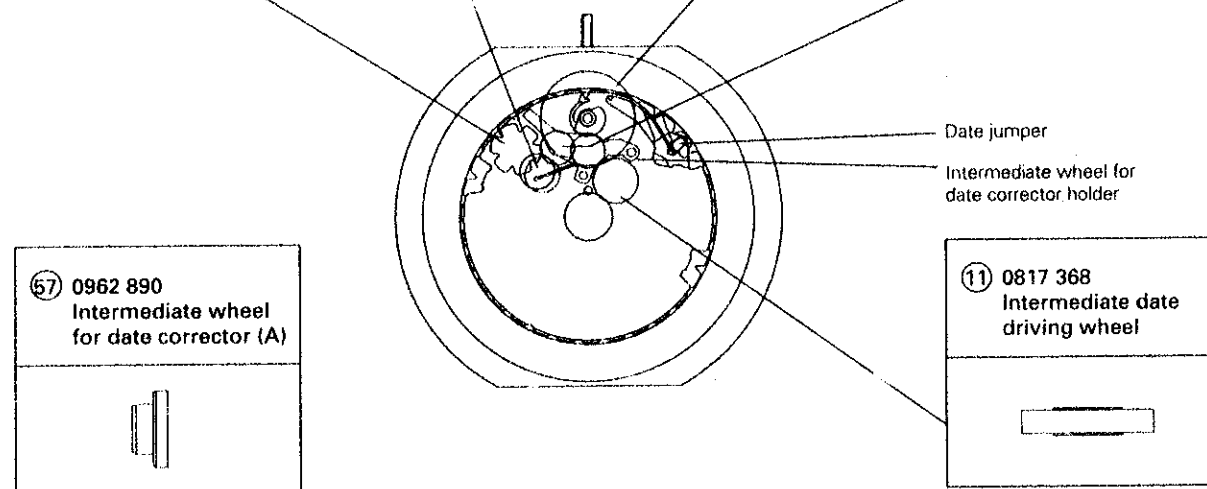



# TECHNICAL GUIDE

Cal. V657A

## ⑦ Auxiliary train wheel bridge

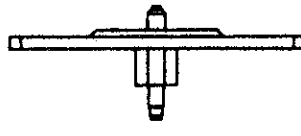
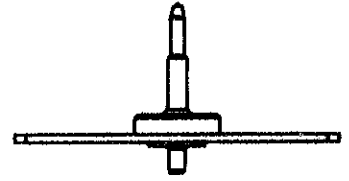
### • Setting position (Stopwatch mechanism)

|   |   |
|---|---|
| ⑰ 0886 002<br>Intermediate chronograph minute wheel and pinion (B)                  | ⑱ 0902 006<br>Chronograph minute wheel  |
|  |  |

|  |
|--|
| ⑲ 0886 001<br>Intermediate chronograph minute wheel and pinion (A)                   |
|  |

|   |
|---|
| ⑳ 0885 357<br>Intermediate chronograph second wheel                                   |
|  |

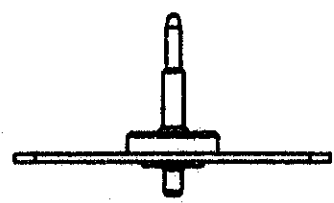
|   |
|---|
| ㉑ 0888 006<br>Chronograph second wheel  |
|  |

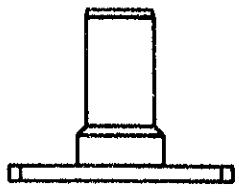
|   |
|---|
| ㉒ 0271 407<br>Hour wheel  |
|  |

# TECHNICAL GUIDE

Cal. V657A

## 23 Battery

### • How to remove

Using tweezers, catch the protrusion of the switch spring indicated in the illustration below, and detach the hooking portion from the main plate. Then, remove the battery.

### • How to install

Slip the battery sideways into the gap under the battery clamp of the switch spring. Then push the battery clamp so that the hooking portion catches the main plate securely.

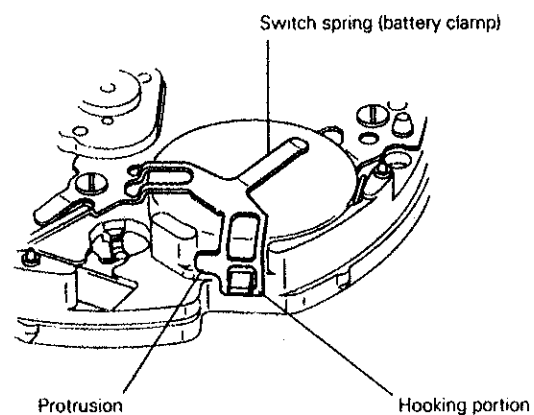

## 24 Winding stem

### • How to remove

Remove the winding stem with the crown at the normal position while pushing the setting lever (marked with "PUSH").

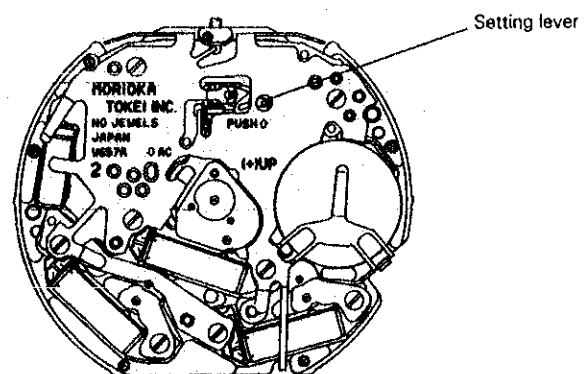

# TECHNICAL GUIDE

Cal. V657A

## 43 Train wheel bridge (A)

## 32 38 Train wheel bridge (B)

### • Setting position

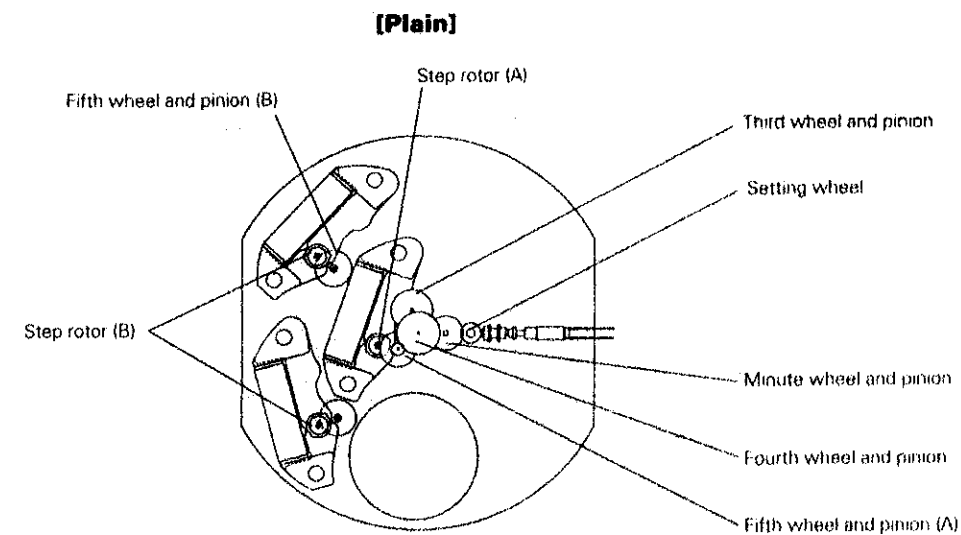

### [Cross section]

#### Train wheel bridge (A)

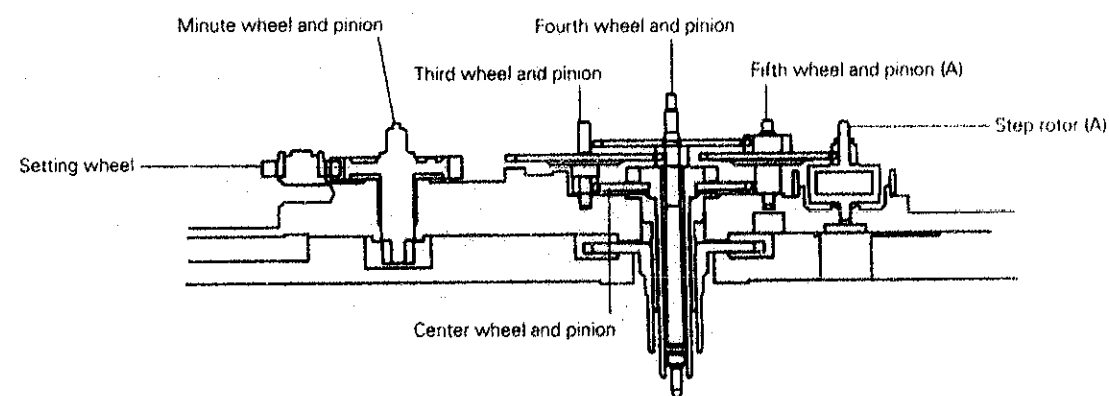

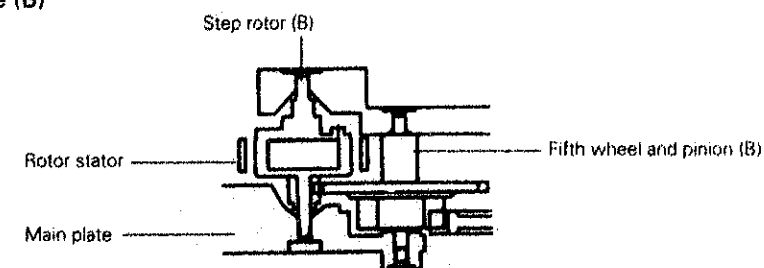

#### Train wheel bridge (B)



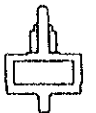

# TECHNICAL GUIDE

Cal. V657A

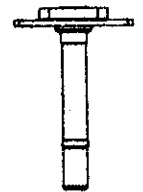
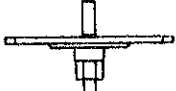
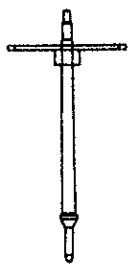
• Distinction of wheels

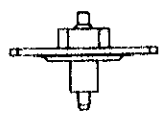
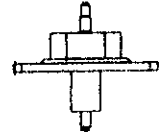
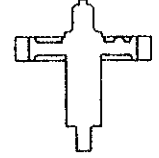
| Parts     | Step rotor (A)  | Step rotor (B)  | Center wheel and pinion   | Third wheel and pinion   | Fourth wheel and pinion   |
|-----------|---|---|---|--|---|
| Shape     |  |  |  |  |  |
| Parts No. | 4146 890  | 4146 177  | 0221 368  | 0231 890   | 0241 407  |

| Parts     | Fifth wheel and pinion (A)  | Fifth wheel and pinion (B)  | Minute wheel and pinion   | Setting wheel  |
|-----------|---|---|---|--|
| Shape     |  |  |  |  |
| Parts No. | 0701 890  | 0701 357  | 0261 176  | 0281 890   |

**Remarks:**

Reassemble the step rotor (B) with its pinion facing the main plate side.

# TECHNICAL GUIDE

Cal. V657A

- ⑤3 Train wheel setting lever
- ⑤4 Setting lever
- ⑤5 Yoke

• Setting position

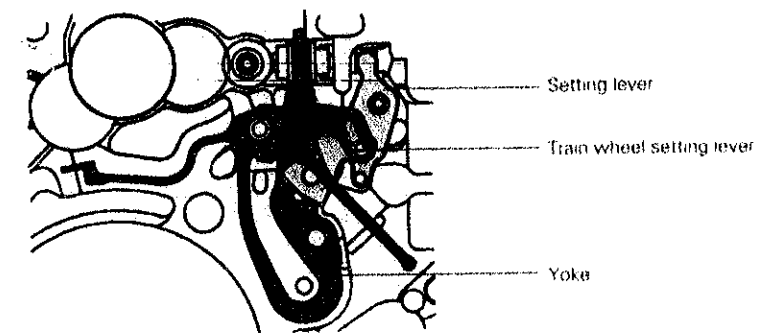

**Remarks:**

Check that the contact spring of the yoke is not deformed.

## IV. VALUE CHECKING

• Coil block resistance

1.9KΩ ~ 2.3KΩ

• Measuring time accuracy

When measuring time accuracy, make sure that the stopwatch is stopped. Otherwise, correct accuracy cannot be obtained.

• Current consumption

For the whole movement : Less than 3.0μA  
For the circuit block alone : Less than 1.5μA

**Remarks:**

Before measuring the current consumption, short-circuit the AC terminal of the circuit block and battery connection (+) with conductive tweezers.