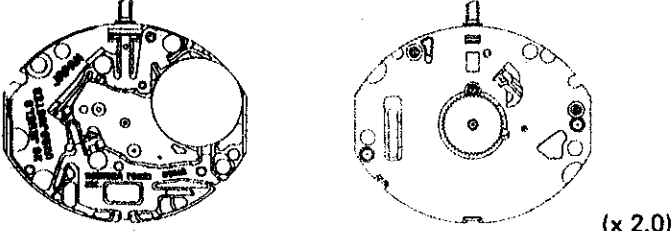

SERVICE GUIDE CAL. V81 SERIES

1. SPECIFICATIONS

Cal. No.		V810	V811
Item	Movement	The illustrations refer to Cal. V811. 	
	Movement size	Outside diameter	φ15.5mm (6h - 12h), 13.0mm (3h - 9h)
		Casing diameter	15.1mm
		Height	3.0mm
Time indication		2 hands (Hands move at 1-sec. intervals.)	3 hands
Driving system		Step motor (Load compensated driving pulse type)	
Additional mechanism		Electronic circuit reset switch	
Loss/gain		Monthly rate: Less than 30 seconds at normal temperature range	
Regulation system		Nil	
Measuring gate by Quartz Tester		10-second gate	
Battery		SEIKO TR527SW MAXELL SR527SW SONY SR527SW EVEREADY 319 Voltage 1.55V Battery life is approximately 2 years for SEIKO TR527SW, and approximately 1.5 years for the other batteries.	
Jewels		0 jewel	

2. REMARKS ON AFTER-SALES SERVICING

- Train wheel bridge, circuit block, battery connection (-), etc. in Cal. V810 and V811 are fixed by heat-treatment, and no screws are used. Therefore, disassembling or assembling of the movement is impossible. If the movement is found out of order, replace it with a new one.
- Winding stem is available for supply. The type of winding stem is determined based on the design of case and dial. Check the case number and refer to "Casing Parts Catalogue" to choose a corresponding winding stem.

3. VALUE CHECKING

- Current consumption

Use the SEIKO Digital Multi Tester S-840A (with Multi Adaptor MA-40A).

Range to be used: μA	Result:
Red probe Battery connection (+)	For the whole movement Less than $1.4\mu\text{A}$
Black probe Battery connection (-)	

4. NOTES ON REPLACING MOVEMENT

- 1) How to remove the winding stem

- While pushing the indented portion of the battery connection (+) (indicated by the arrow in the illustration at right), pull out the winding stem.
- Do not lubricate the winding stem.

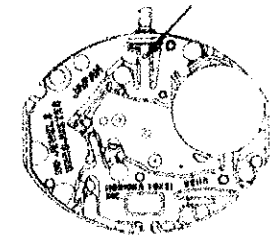

- 2) Notes on installing the hands

For Cal. V81 series, if the hands are installed through the conventional procedures, the minute hand may slightly move when the crown is pushed back to the normal position after the time setting. To minimize such movement of the minute hand, follow the procedures below to install the hands.

1. Install the battery and dial on the movement and start the watch operation.
2. Remove the battery when one of the guide holes of the third wheel and pinion and the guide hole of the train wheel bridge completely overlap with each other, having a common center. While doing so, be sure to keep the crown at the normal position.

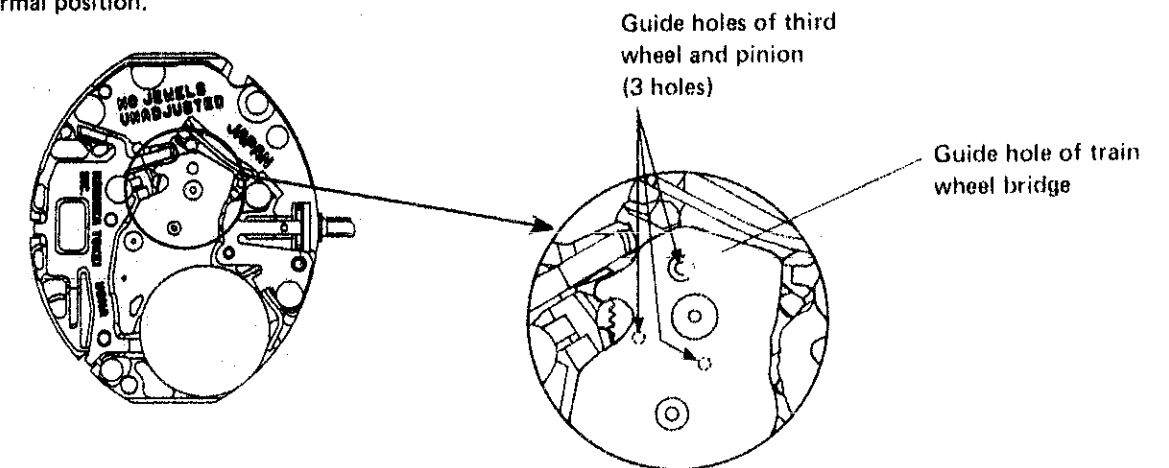

3. Be sure to install the hour, minute and second hands so that they point to the 12 o'clock position. While doing so, do not operate the crown. Then, support the movement directly with a flat solid material (stainless steel plate, etc.) to press in the hands, as the train wheel bridge for Cal. V810 and V811 is made of plastics.

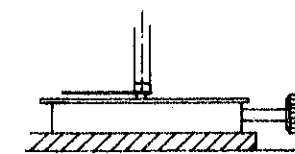

4. Check again that the guide hole of the third wheel and pinion and the guide hole of the train wheel bridge have a common center. If otherwise, repeat the procedures again from the step "1".

Note: For another method of installing the hands, refer to "HAND INSTALLATION FOR CAL. V51 SERIES: PROCEDURE AND REMARKS" in Service Bulletin No. 6 (June 1987).