

EBAUCHES SA NEUCHATEL SWITZERLAND



Fontainemelon Watch Manufacturing Co.

LE LANDERON Branch, Le Landeron

11¹/₂ 4751

25.60 mm.

Enlarged view
of movement

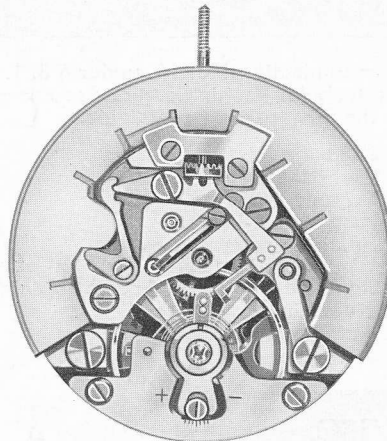

Fig. 1

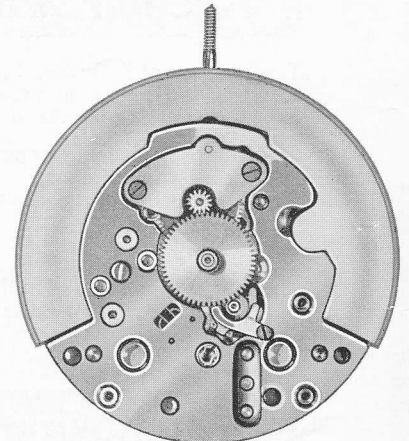

Fig. 2

Electro-mechanical watch

Sweep second, stop device of the balance

Technical and practical communication for the use of the watch repairer

Copyright 1963 by Ebauches S.A. Neuchâtel (Switzerland). 1st edition, January 1963.

Reproduction prohibited. Published by Ebauches S.A. (French, English, German, Italian, Spanish).

1. Introduction

This Technical Communication deals with the addition of a balance stop mechanism, the use of a new cell as a source of power and various technical improvements made in the caliber L-4750, Swiss Electric Watch, resulting in alteration of its reference number to L-4751.

This is therefore complementary to Technical Communication No. 16 and pertains only to the alterations and improvements referred to above. However Technical Communication No. 16 should be referred to whenever it is indicated.

2. Feed

2. 1. Type of feed

Caliber L-4751 is usually fed by a Mallory WD-5 cell, which supplies current at 1.35 volt (an excess of 0.2 volt may be noted when the cell is very fresh). This cell enables the movement to run for two years.

2. 2. Replacing the cell

When the movement is fitted with a WD-5 cell, replacement is made by a watchmaker. To do this, see chapter 4 : Removing the case. Usually this operation will coincide with the overhauling of the movement.

3. Tools, material and instruments recommended for repair work

The equipment described in Technical Communication No. 16, under § 3. 1. and 3. 2., is perfectly suitable for repairing caliber L-4751, but is intended more particularly for Repair Centers. For this reason, EBAUCHES SA has brought out a less expensive version for the watchmaker, in the form of a kit containing:

1 universal measuring apparatus
(for checking voltages,
resistances and the consumption
of the movement).

2 spare cells
1 set of spare parts
1 simple feed ring
1 movement-holder
1 plastic protective cover

1 feed plate
1 pair of contact tweezers
1 pair of non-magnetic tweezers
1 set of technical information

This kit is supplied under the name "Kit Standard L-4751" and can be obtained from watch-material dealers. Distributor: EBAUCHES SA, Spare Parts Department, Neuchâtel, Switzerland.

4. Removing the case

The method of fixing the movement in the case varies according to the various casing systems used. Described below are two systems commonly used.

4. 1. Two-piece case, fig. 3

Remove the back of the case.
Remove the feed bridle for dry cell No. 4035.
Remove the feed bridle insulator No. 4045.
Remove the combined setting and stop lever No. 473.
Withdraw the hand-setting stem No. 405.
Withdraw the hand-setting pinion No. 412.
Remove the two casing clamps No. 166.
Take the movement out of the case and place it on the flat side of the movement holder, with its dial upwards.
Remove the hands and dial.
Remove the casing bridle No. 960.
Unscrew the 2 screws of the plate-enlargement ring No. 5158.
Withdraw the plate-enlargement ring No. 158.

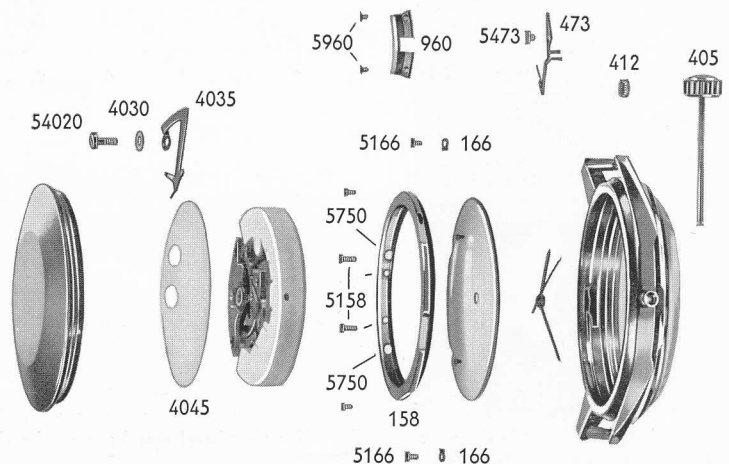

Fig. 3

4. 2. Replacing the dry cell

Remove the bolt No. 4926 by gripping it by its catches with a pair of tweezers.
Remove the cell-maintaining ring No. 4925.
Take out the cell.

Note: To fit the new cell, reverse the above procedure. Be sure to observe the strictest cleanliness.

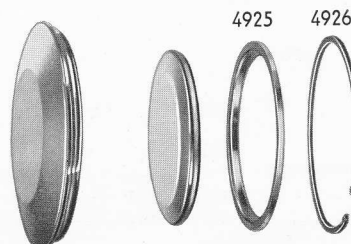

Fig. 4

4. 3. One-piece case (single shell), fig. 5

Note: this case is fitted with a two-piece handsetting stem.

Pull hard on the hand-setting stem to take out the waterproof crown stem No. 963.

Push back the stem for waterproof case No. 404, which remains fixed to the movement.

Remove the crystal with a special wrench.

Turn the case over carefully; the movement should come away, followed by the cell-compensating spring No. 4924 and the cell itself.

Place the movement on the flat side of the movement-holder, with its dial upwards.

Remove the hands and dial.

Turn the movement over and remove the feed bridle for dry cell No. 4035, as well as the feed bridle insulator No. 4045.

Remove the casing bridle No. 960.

Unscrew the 2 screws of the plate-enlargement ring No. 5158.

Remove the plate-enlargement ring No. 158.

Remove the combined setting and stop lever No. 473.

Withdraw the stem for waterproof case No. 404. Remove the hand-setting pinion No. 412.

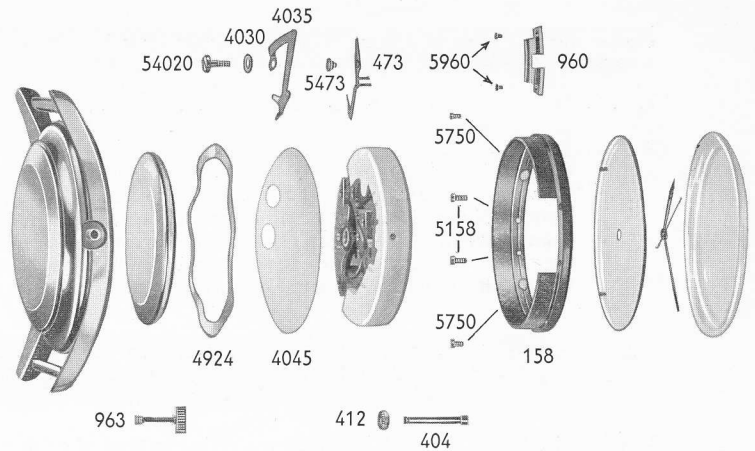

Fig. 5

5. Overhauling the movement

All the operations described in Technical Communication No. 16, chapter 5, § 5. 1. to 5. 13., are identical for caliber L-4751, with the exception of § 5. 9., which is replaced by:

5. 14. Assembling the hand-setting mechanism and adjusting the balance stop action.

Note: this operation is effected after the balance has been fitted and the general lubrication has been completed.

Insert the hand-setting pinion No. 412, lubricate the hand-setting stem No. 405 and place it in position. Screw on the combined setting and stop lever No. 473. Lubricate the functional parts of the setting and stop lever and the setting lever spring No. 445.

The combined setting and stop lever must work freely without any endshake, to avoid any longitudinal shift of the stop spring fixed to the end of the setting and stop lever, which would have the undesirable effect of releasing the balance too early.

When the hand-setting stem is pulled out, the position of the combined setting and stop lever corresponds to the balance stop function. At that moment, the tip of the stop spring should strike about halfway up the stop pin (see fig. 6) on the rim of the balance. This action is adjusted by bending the stop spring. The stop pin should never be removed, otherwise it might work loose in the rim of the balance.

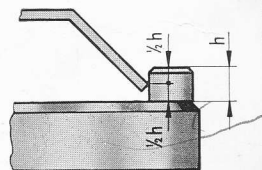

Fig. 6

6. Checking the finished movement

Due to improvements made in caliber L-4751, the values of the feed voltage and consumption, in the table in chapter 6 of Technical Communication No. 16, have been modified. In place of this are the indications given in the table below:

POSITION	VOLTAGE	AMPLITUDE	CURRENT-CONS.
H B	1,4 V	290° to 320°	
V B	1,4 V	< 240°	Less than 15 μ A

Fig. 7

For all information regarding the checking of the finished movement, please consult chapter 6, § 6. 1. of Technical Communication No. 16.

7. Fitting the dial and hands - Casing up - Final checking

7. 1. Two-piece case

7. 1. 1. Place in position and screw on the plate-enlargement ring. Fit the casing bridle No. 960 to the plate-enlargement ring. Drive home the two screws of the plate-enlargement ring No. 5158. Place in position the hour wheel No. 255 and its dial washer. The latter should have a slight amount of tension. (If this has been lost, it is important to replace it, using a dial washer that is sufficiently weak, so as not to form an additional brake.) Fit the dial and hands.
7. 1. 2. Remove the combined setting and stop lever No. 473, the hand-setting stem No. 405 and the hand-setting pinion No. 412. Place the movement in the case, which should first be carefully cleaned. Refit the hand-setting stem, the hand-setting pinion and the combined setting and stop lever. Fix the movement in the case with the casing clamps and their screws Nos. 166 and 5166. Fit the feed bridle insulator No. 4045 and screw on the feed bridle for dry cell No. 4035. The second hole of the insulator gives access to the adjuster for regulator.
7. 1. 3. Check the voltage of the dry cell with the measuring apparatus, according to the indications given in § 2. 1. Fit the cell into the bottom of the case. Check the working of the balance stop mechanism. Place the watch in a demagnetizing machine. Check and adjust the instantaneous rate and the timing.
7. 1. 4. If the watch stops, there may be:
 - a) a defect in the feed system
 - b) a stoppage in the gear train.

In the case of (a), see that the dry cell is correctly fitted in the bottom of the case (the \oplus pole of the cell should rest against the bottom of the case). Check that the voltage measured between the bottom of the case (\oplus pole) and the middle portion of the cell (\ominus pole), on which the feed bridle rests, corresponds to the indications given in § 2. 1. Make sure too that the feed bridle has sufficient tension and is properly centered in relation to the movement.

If the watch still fails to work despite these checks, remove the balance and check the continuity of the circuit. For this purpose, see Technical Communication No. 16, § 5. 8. It is not necessary to take the movement out of the case.

7. 1. 5. In case (b), the ticking of the watch is heard, but the hands do not turn. This is due to a mechanical stoppage caused by the click wheel, which is not driven by the click lever. Check the hands and see that train is perfectly clean (see CT No. 16, chapter 5. 4.).

7. 2. One-piece case

7. 2. 1. Place the movement on the movement-holder, with its dial side downwards. Fit the feed bridle insulator and screw on the feed bridle for dry cell. The second hole of the feed bridle insulator gives access to the adjuster for regulator.
7. 2. 2. See § 7. 1. 1. above.
7. 2. 3. Check the voltage of the dry cell with the measuring instrument, according to the indications given in § 2. 1. When you have made sure that the case is perfectly clean, insert the dry cell, seeing that its \oplus pole rests against the bottom of the case; fit the compensating spring for the cell No. 4924 insert the movement and fit the crystal with the special wrench. Insert the hand-setting crown by pushing it hard, and check the proper working of the hand-setting mechanism and the balance stop system. Then place the watch in a demagnetizing machine. Check and adjust the timing. If the watch fails to work, movement must be taken out the case, and see § 7. 1. 4. and 7. 1. 5. above.

8. Description and functioning

The functioning of the watch L-4751 is similar to that of caliber L-4750, described in chapter 8 of Technical Communication No. 16. Described below is only the functioning of the balance stop system applicable to caliber L-4751.

When the hand-setting stem is pulled out, the pin fixed on the rim of the balance strikes the stop spring of the combined setting and stop lever. This stops the balance outside its position of equilibrium; the contact is open (the contact finger is not resting on the contact springs) and the cell supplies no current.

When the hand-setting stem is pushed back, the balance at once starts to swing due to the effect of the hairspring. This system enables the user to set his watch accurately (to the nearest second) and to make time measurements. It also enables the watchmaker to disconnect the dry cell when the watch is being kept in stock.

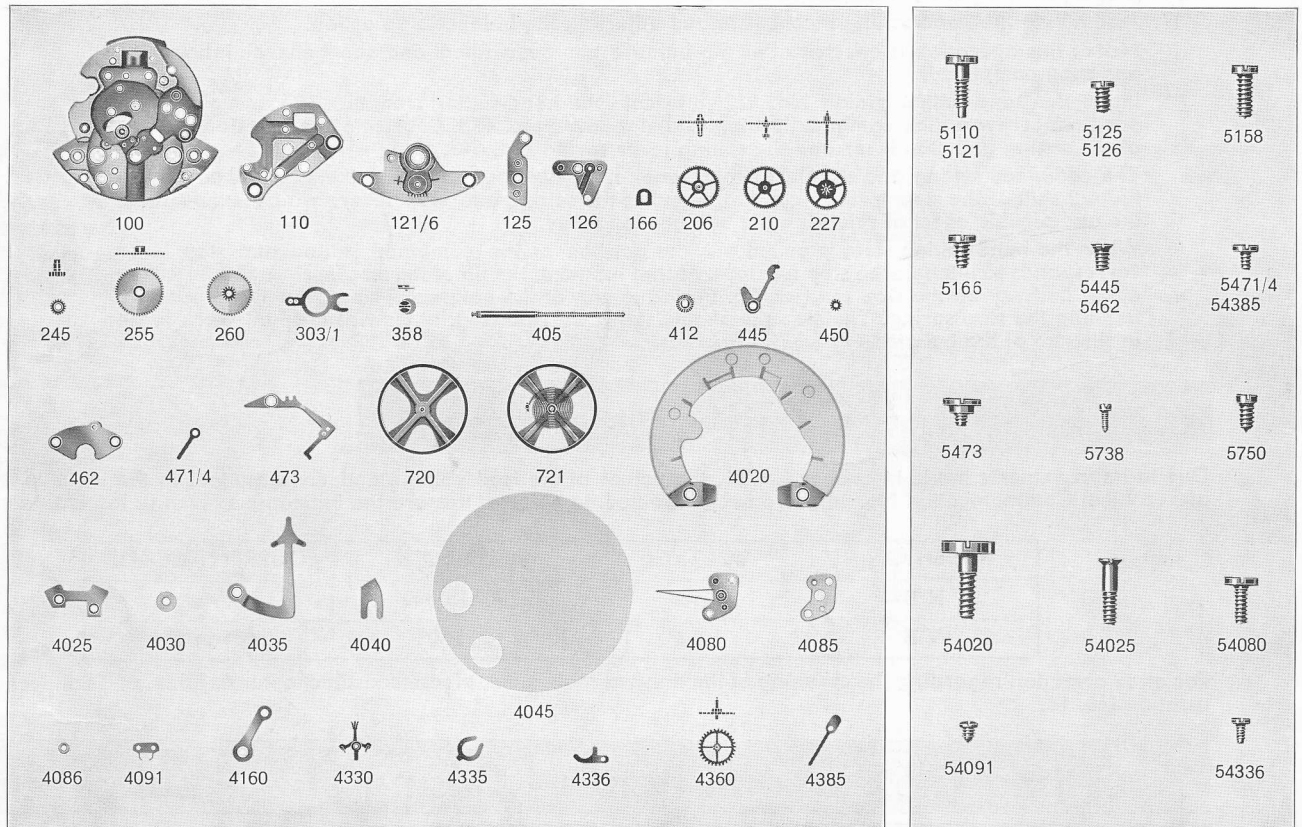

LIST OF MATERIALS

No.	No.	No.
* 100 Plate	471/4 Friction spring for sweep second wheel	4385 Friction spring for click wheel
* 110 Train wheel bridge	* 473 Setting and stop lever	5110 Train wheel bridge screw
* 121/6 Balance cock for regulating and shock-protecting devices, flat hairspring	* 720 Pivoted balance with roller, contact finger and banking pin	5121 Balance cock screw
125 Pallet cock	* 721 Balance with flat hairspring, regulated	5125 Pallet cock screw
* 126 Center wheel cock	4020 Motor stator, mounted	5126 Screw for center wheel cock
* 166 Casing clamp	4025 Stator fixing clamp	5158 Plate-enlargement ring screw
206 Center wheel	4030 Stator screw insulator	* 5166 Casing clamp screw
210 Third wheel	* 4035 Power connection for battery watch	5445 Screw for setting lever spring
227 Sweep second wheel	4040 Stator spacing washer	5462 Screw for minute work cock
245 Cannon pinion	* 4045 Power connection insulator	5471/4 Screw for sweep second wheel friction spring
255 Hour wheel	4080 Contact, assembled	* 5473 Setting and stop lever screw
260 Minute wheel	4085 Contact insulator, lower	5738 Hairspring stud screw
303/1 Two-piece regulator for regulating device, flat hairspring	4086 Contact screw insulator	5750 Dial screw
358 Adjuster for regulator	4091 Contact plate	54020 Screw for motor stator
* 405 Hand-setting stem	4160 Lead	54025 Screw for stator fixing clamp
* 412 Hand-setting pinion	4330 Click lever, mounted	54080 Screw for assembled contact
445 Setting lever spring	4335 Lever magnet	54091 Contact plate screw
450 Setting wheel	* 4336 Clamp for lever magnet	* 54336 Clamp screw for lever magnet
* 462 Minute work cock	4360 Click wheel, pivoted	54385 Screw for click wheel friction spring

* These parts are not interchangeable with those of caliber L. 4750